

**Doc. Number :**

- Tentative Specification  
 Preliminary Specification  
 Approval Specification

**MODEL NO.: M215HCJ**  
**SUFFIX: L3N**

**Customer:**
**APPROVED BY**
**SIGNATURE**
**Name / Title** \_\_\_\_\_

Note

Product Version C1

Please return 1 copy for your confirmation with your signature and comments.

Approved By	Checked By	Prepared By
阮泰郎	陳立錚	耿振唐

## CONTENTS

<b>1. GENERAL DESCRIPTION .....</b>	<b>5</b>
1.1 OVERVIEW .....	5
1.2 GENERAL SPECIFICATIONS .....	5
<b>2. MECHANICAL SPECIFICATIONS .....</b>	<b>5</b>
<b>3. ABSOLUTE MAXIMUM RATINGS .....</b>	<b>6</b>
3.1 ABSOLUTE RATINGS OF ENVIRONMENT .....	6
3.2 ELECTRICAL ABSOLUTE RATINGS .....	6
3.2.1 TFT LCD MODULE .....	6
3.2.2 BACKLIGHT UNIT .....	7
<b>4. ELECTRICAL SPECIFICATIONS .....</b>	<b>8</b>
4.1 FUNCTION BLOCK DIAGRAM .....	8
4.2. INTERFACE CONNECTIONS .....	9
4.3 ELECTRICAL CHARACTERISTICS .....	10
4.3.1 LCD ELETRONICS SPECIFICATION .....	10
4.3.2 VCC POWER DIP CONDITION .....	13
4.3.3 BACKLIGHT UNIT .....	13
4.3.4 LIGHTBAR CONNECTOR PIN ASSIGNMENT .....	14
4.4 LVDS INPUT SIGNAL SPECIFICATIONS .....	15
4.4.1 LVDS DATA MAPPING TABLE .....	15
4.4.2 COLOR DATA INPUT ASSIGNMENT .....	16
4.5 DISPLAY TIMING SPECIFICATIONS .....	17
4.6 POWER ON/OFF SEQUENCE .....	19
<b>5. OPTICAL CHARACTERISTICS .....</b>	<b>20</b>
5.1 TEST CONDITIONS .....	20
5.2 OPTICAL SPECIFICATIONS .....	20
<b>6. RELIABILITY TEST ITEM .....</b>	<b>23</b>
<b>7. MECHANICAL STRENGTH CHARACTERISTICS .....</b>	<b>24</b>
7.1 MECHANICAL STRENGTH SPECIFICATIONS .....	24
7.2 TEST CONDITIONS .....	24
7.3 DEFINITION OF TEST POINTS .....	24
<b>8. PACKING .....</b>	<b>25</b>
8.1 PACKING SPECIFICATIONS .....	25
8.2 PACKING METHOD .....	25
8.3 PALLET .....	26
8.4 UN-PACKING METHOD .....	27

<b>9. INX MODULE LABEL</b> .....	<b>28</b>
<b>10. PRECAUTIONS</b> .....	<b>29</b>
10.1 ASSEMBLY AND HANDLING PRECAUTIONS .....	29
10.2 STORAGE PRECAUTIONS .....	29
10.3 OPERATION PRECAUTIONS .....	30
10.4 SAFETY PRECAUTIONS .....	30
10.5 SAFETY STANDARDS .....	30
10.6 OTHER .....	30
<b>Appendix 1. SYSTEM COVER DESIGN NOTICE</b> .....	<b>31</b>
<b>Appendix 2. OUTLINE DRAWING</b> .....	<b>34</b>

www.58display.com

**REVISION HISTORY**

Version	Date	Page	Description
0.0	Aug.31, 2016	All	Spec Ver.0.0 was first issued.
1.0	Nov.16, 2016	All	Spec Ver.1.0 was first issued.
2.0	Mar. 27 2017	All	Spec Ver.2.0 was first issued.
3.0	Apr. 18 2017	All	Spec Ver.3.0 was first issued.

## 1. GENERAL DESCRIPTION

### 1.1 OVERVIEW

M215HCJ-L3N is a 21.5" TFT Liquid Crystal Display MNT module with WLED Backlight unit and 30 pins 2ch-LVDS interface. This module supports 1920 x 1080 Full HD mode and can display up to 16.7M colors. The converter module for Backlight is not built in.

### 1.2 GENERAL SPECIFICATIONS

Item	Specification	Unit	Note
Screen Size	21.5" real diagonal		
Driver Element	a-si TFT active matrix	-	-
Pixel Number	1920 x R.G.B. x 1080	pixel	-
Pixel Pitch	0.24795 (H) x 0.24795 (V)	mm	-
Pixel Arrangement	RGB vertical stripe	-	-
Display Colors	16.7M(8bit)	color	-
Transmissive Mode	Normally Black	-	-
Surface Treatment	AG type, 3H hard coating, Haze 25	-	-
Luminance, White	250	Cd/m2	
Color Gamut	72% of NTSC(Typ.)	-	-
Display Orientation	Signal input with " INX"		(2)
RoHS,Halogen Free &TCO 6.0	RoHS, Halogen Free TCO 6.0 compliance		
Power Consumption	Total 15.93W (Max.) @ cell 4.05W (Max.), BL 11.88W (Max.)		(1)

Note (1) The specified power consumption : Total= cell (reference 4.3.1)+BL (reference 4.3.3)

Note (2)

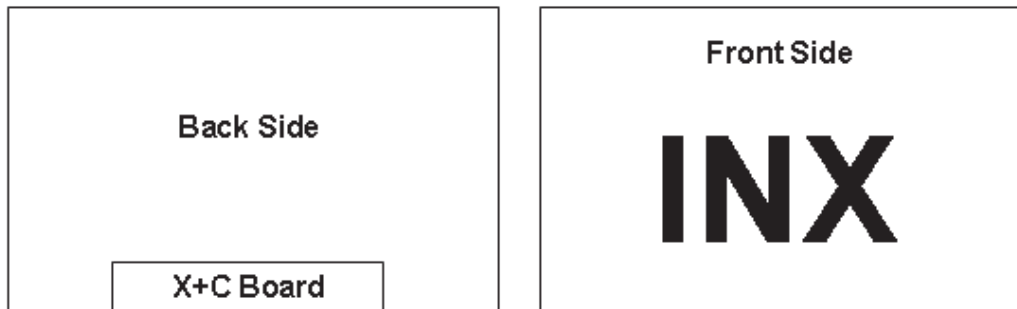

## 2. MECHANICAL SPECIFICATIONS

Item	Min.	Typ.	Max.	Unit	Note	
Module Size	Horizontal (H)	488.8	489.3	489.8	mm	(1)
	Vertical (V)	286.5	287	287.5	mm	
	Thickness (T)	12.3	12.8	13.3	mm	
Bezel Area	Horizontal	478.8	479.3	479.8	mm	
	Vertical	270.4	270.9	271.4	mm	
Active Area	Horizontal	-	476.064	-	mm	
	Vertical	-	267.786	-	mm	
Weight	1665	1850	1942	g		

Note (1) Please refer to the attached drawings for more information of front and back outline dimensions.

### 3. ABSOLUTE MAXIMUM RATINGS

#### 3.1 ABSOLUTE RATINGS OF ENVIRONMENT

Item	Symbol	Value		Unit	Note
		Min.	Max.		
Storage Temperature	TST	-20	60	°C	(1)
Operating Ambient Temperature	TOP	0	50	°C	(1), (2)

Note (1)

(a) 90 %RH Max.

(b) Wet-bulb temperature should be 39 °C Max.

(c) No condensation.

Note (2) Panel surface temperature should be 0°C min. and 65°C max under Vcc=5.0V, fr =60Hz, typical LED string current, 25°C ambient temperature, and no humidity control . Any condition of ambient operating temperature ,the surface of active area should be keeping not higher than 65°C.

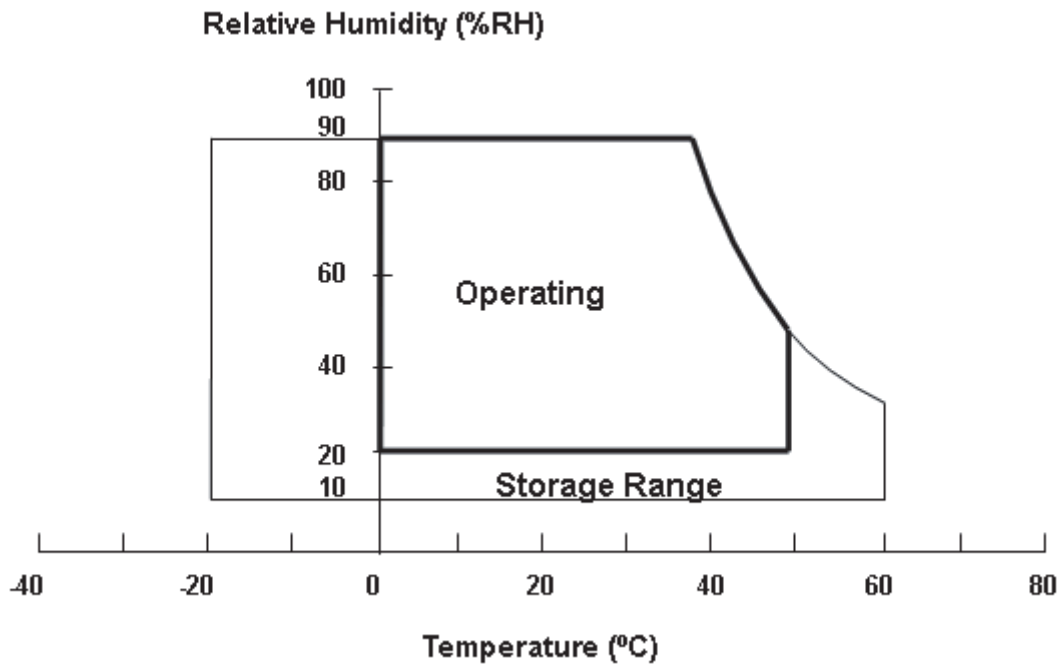

### 3.2 ELECTRICAL ABSOLUTE RATINGS

#### 3.2.1 TFT LCD MODULE

Item	Symbol	Value		Unit	Note
		Min.	Max.		
Power Supply Voltage	VCCS	-0.3	6.0	V	(1)
Logic Input Voltage	V <sub>IN</sub>	-0.3	3.6	V	

### 3.2.2 BACKLIGHT UNIT

Item	Symbol	Value			Unit	Note
		Min.	Typ	Max.		
LED Forward Current Per Input Pin	$I_F$	---	50	55	mA	(1), (2) Duty=100%
LED Reverse Voltage Per Input Pin	$V_R$	---	---	---	V	
LED Pulse Forward Current Per Input Pin	$I_P$	---	---	500	mA	(1), (2) Pulse Width $\leq$ 10msec. and Duty $\leq$ 10%

Note (1) Permanent damage to the device may occur if maximum values are exceeded. Function operation should be restricted to the conditions described under Normal Operating Conditions.

Note (2) Specified values are for input pin of LED light bar at  $T_a=25\pm 2$  °C (Refer to 4.3.3 and 4.3.4 for further information).

4. ELECTRICAL SPECIFICATIONS

4.1 FUNCTION BLOCK DIAGRAM

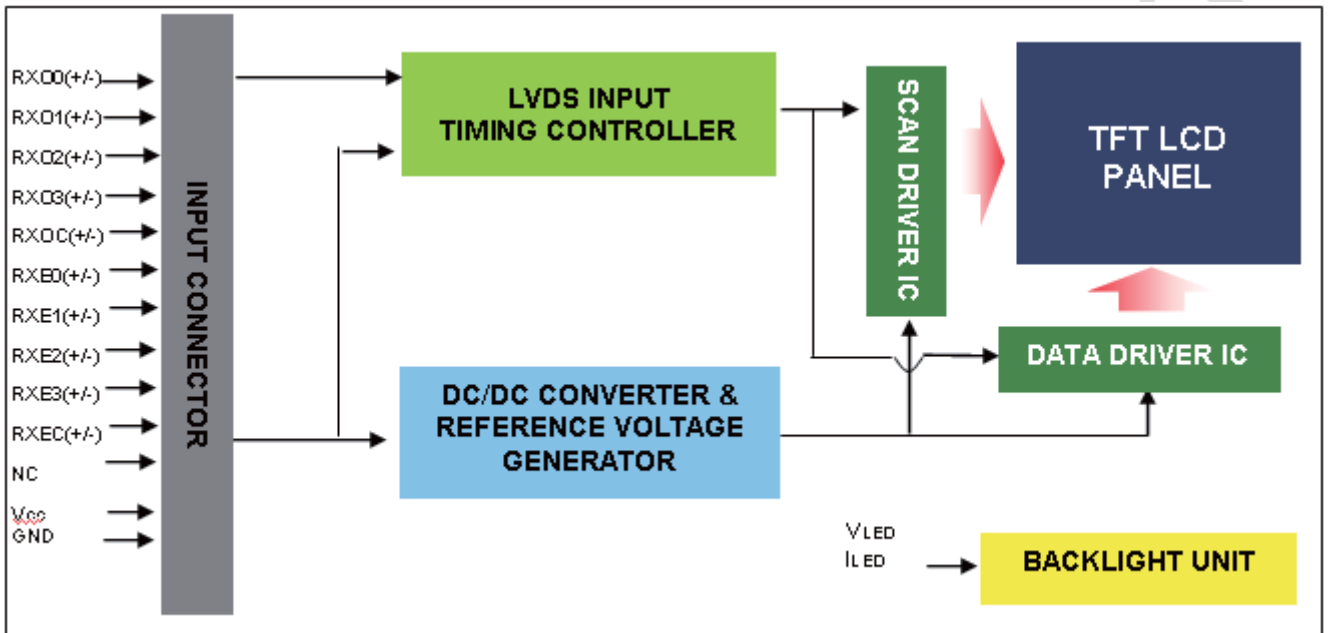

www.58display.com



## 4.2. INTERFACE CONNECTIONS

### PIN ASSIGNMENT

Pin	Name	Description
1	RXO0-	Negative LVDS differential data input. Channel O0 (odd)
2	RXO0+	Positive LVDS differential data input. Channel O0 (odd)
3	RXO1-	Negative LVDS differential data input. Channel O1 (odd)
4	RXO1+	Positive LVDS differential data input. Channel O1 (odd)
5	RXO2-	Negative LVDS differential data input. Channel O2 (odd)
6	RXO2+	Positive LVDS differential data input. Channel O2 (odd)
7	GND	Ground
8	RXOC-	Negative LVDS differential clock input. (odd)
9	RXOC+	Positive LVDS differential clock input. (odd)
10	RXO3-	Negative LVDS differential data input. Channel O3(odd)
11	RXO3+	Positive LVDS differential data input. Channel O3 (odd)
12	RXE0-	Negative LVDS differential data input. Channel E0 (even)
13	RXE0+	Positive LVDS differential data input. Channel E0 (even)
14	GND	Ground
15	RXE1-	Negative LVDS differential data input. Channel E1 (even)
16	RXE1+	Positive LVDS differential data input. Channel E1 (even)
17	GND	Ground
18	RXE2-	Negative LVDS differential data input. Channel E2 (even)
19	RXE2+	Positive LVDS differential data input. Channel E2 (even)
20	RXEC-	Negative LVDS differential clock input. (even)
21	RXEC+	Positive LVDS differential clock input. (even)
22	RXE3-	Negative LVDS differential data input. Channel E3 (even)
23	RXE3+	Positive LVDS differential data input. Channel E3 (even)
24	GND	Ground
25	NC	For LCD internal use only, Do not connect
26	NC	For LCD internal use only, Do not connect
27	NC	For LCD internal use only, Do not connect
28	Vcc	+5.0V power supply
29	Vcc	+5.0V power supply
30	Vcc	+5.0V power supply

Note (1) Connector Part No.:

P-TWO:187098-30091 or FCN:WF13-422-3033 or Foxconn:GS23301-0321R-7H

Note (2) User's connector Part No:

Mating Wire Cable Connector Part No.: FI-X30H(JAE) or FI-X30HL(JAE)

Mating FFC Cable Connector Part No.: 217007-013001 (P-TWO) or JF05X030-1 (JAE).

Note (3) The first pixel is odd.

Note (4) Input signal of even and odd clock should be the same timing.

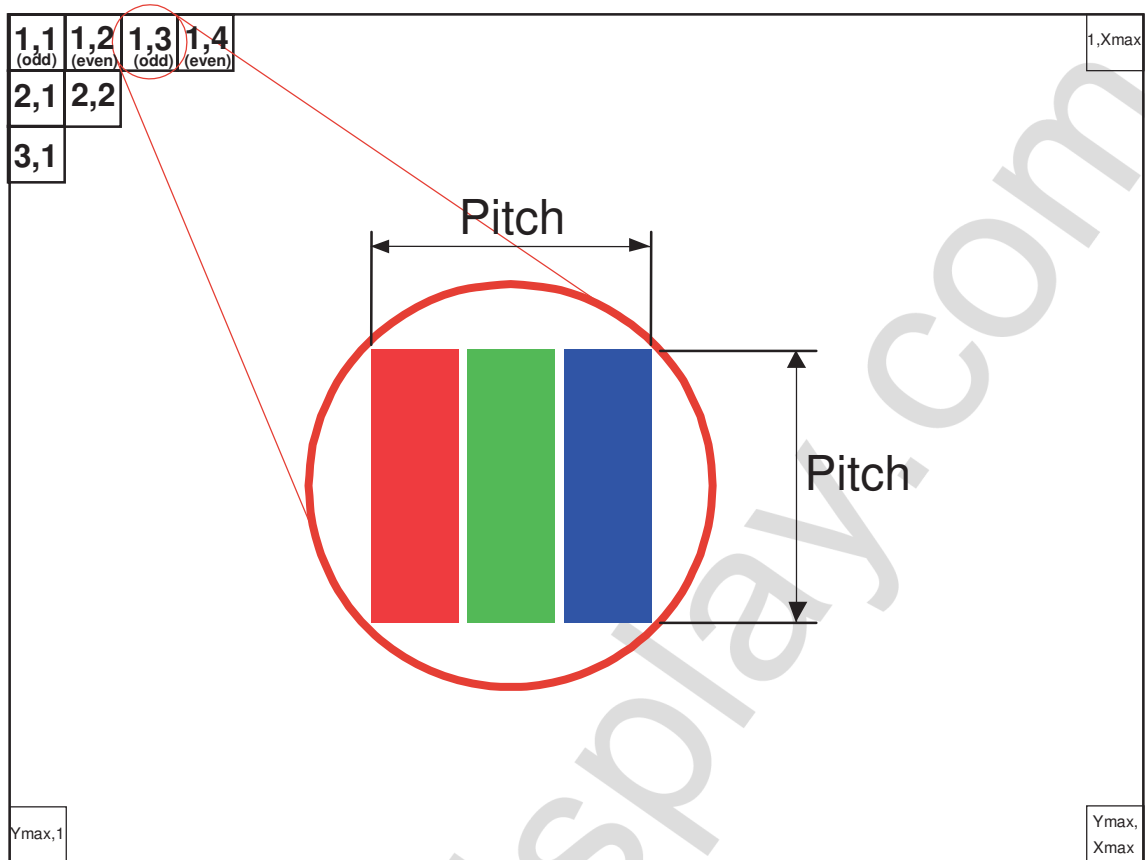

## 4.3 ELECTRICAL CHARACTERISTICS

### 4.3.1 LCD ELETRONICS SPECIFICATION

Parameter	Symbol	Value			Unit	Note	
		Min.	Typ.	Max.			
Power Supply Voltage	V <sub>CC</sub>	4.5	5.0	5.5	V	-	
Ripple Voltage	V <sub>RP</sub>	-	-	300	mV	-	
Rush Current	I <sub>RUSH</sub>	-	-	3	A	(2)	
Power Supply Current	White	-	550	640	mA	(3)a	
	Black	-	530	620	mA	(3)b	
	Vertical Stripe	-	700	810	mA	(3)c	
Power Consumption	PLCD	-	3.5	4.05	Watt	(4)	
LVDS interface	Differential Input Voltage	V <sub>ID</sub>	100	-	600	mV	
	Common Input Voltage	V <sub>CM</sub>	1.0	1.2	1.4	V	
	Differential Input High Threshold Voltage	V <sub>TH</sub>	-	-	+100	mV	
	Differential Input Low Threshold Voltage	V <sub>TL</sub>	-100	-	-	mV	

Note (1) The ambient temperature is  $T_a = 25 \pm 2$  °C.

Note (2) Measurement Conditions:

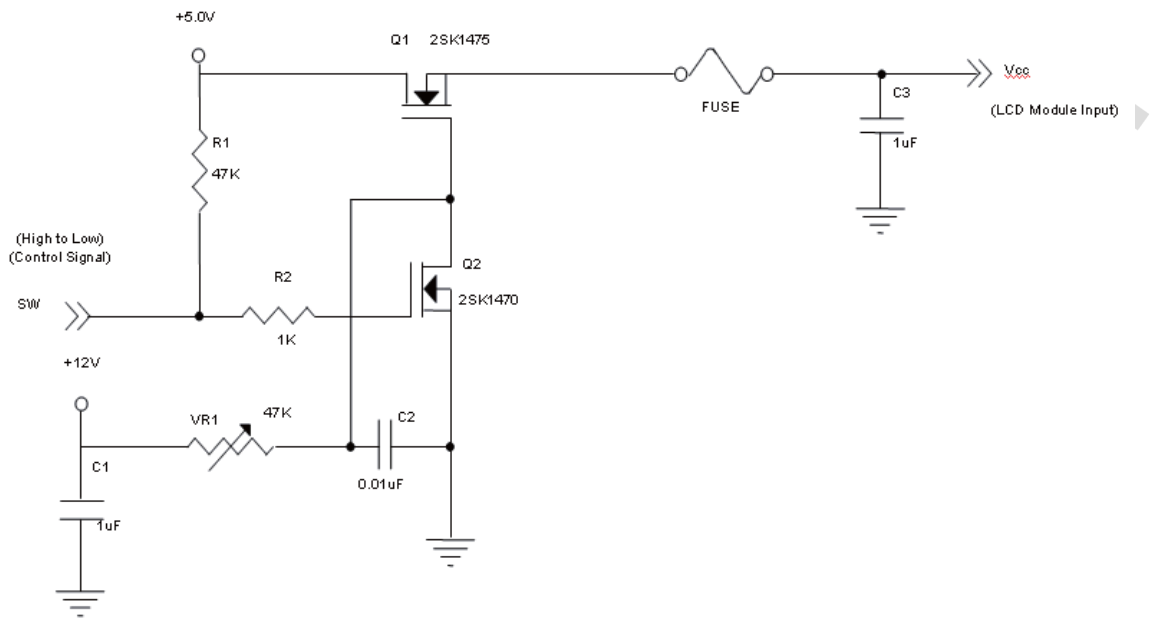

**Vcc rising time is 470μs**

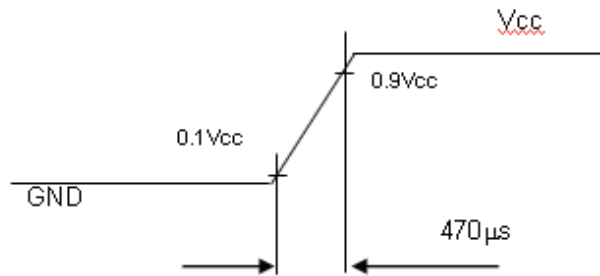

Note (3) The specified power supply current is under the conditions at  $V_{cc} = 5.0\text{ V}$ ,  $T_a = 25 \pm 2\text{ }^\circ\text{C}$ ,  $F_r = 60\text{ Hz}$ , whereas a power dissipation check pattern below is displayed.

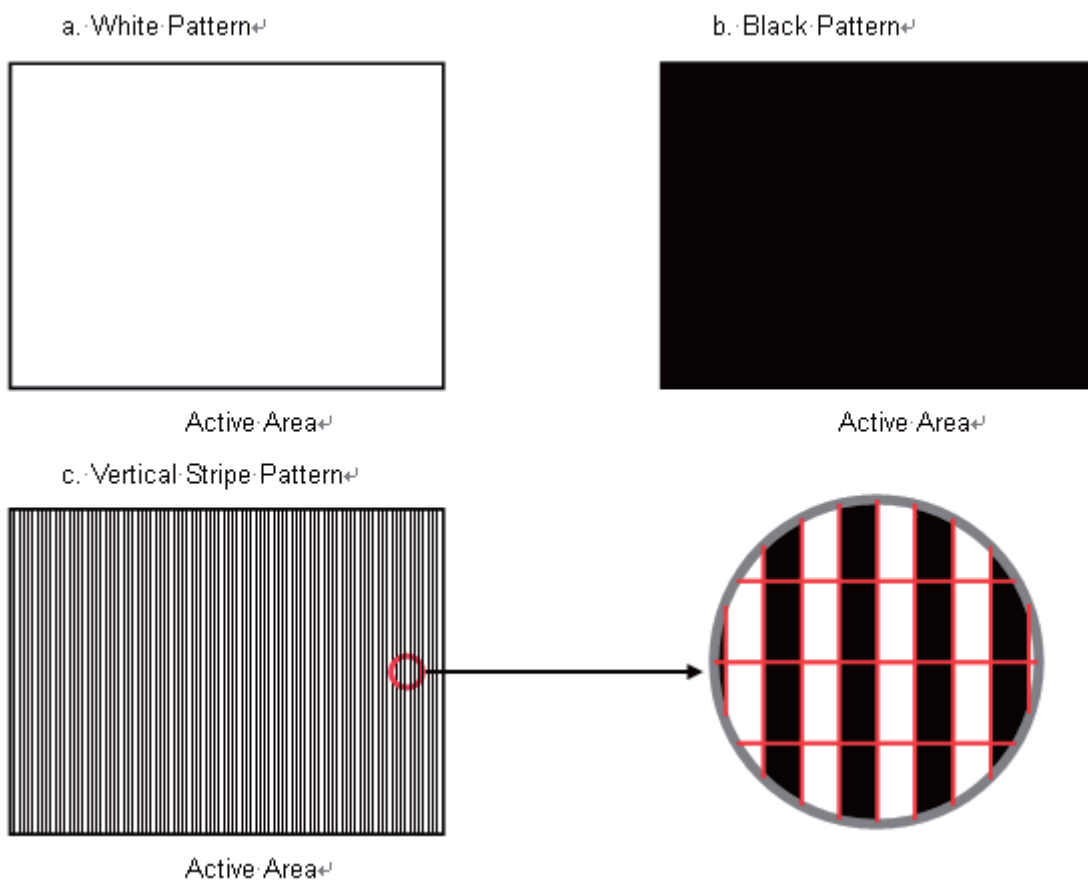

Note (4) The power consumption is specified at the pattern with the maximum current.

Note (5) The LVDS input characteristics are as follows:

**Single-end Signals**

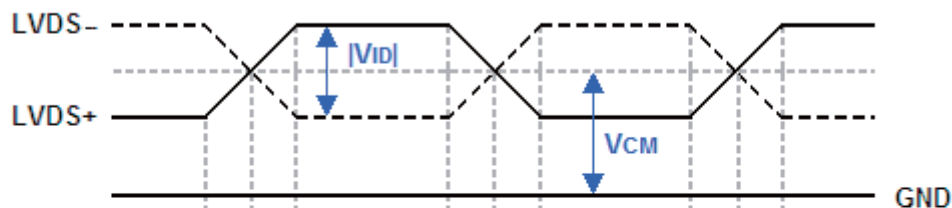

**Differential Signal**

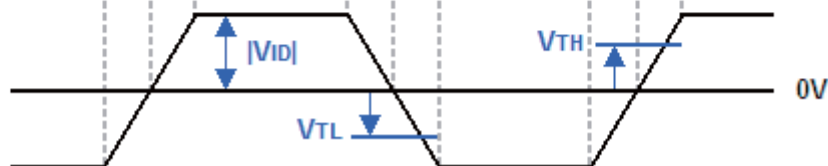

#### 4.3.2 VCC POWER DIP CONDITION

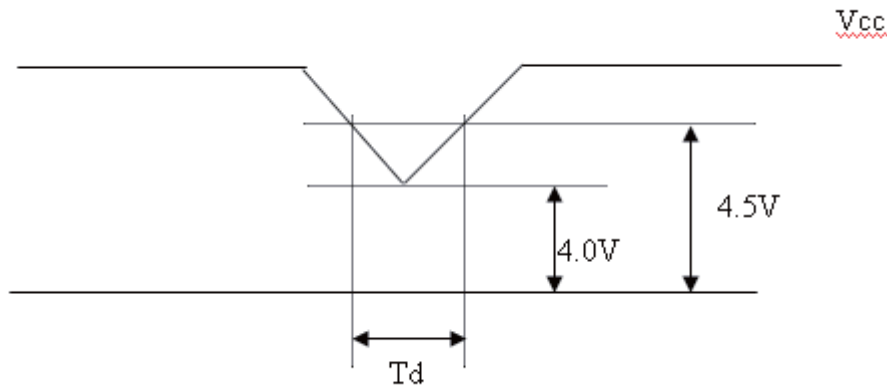

#### 4.3.3 BACKLIGHT UNIT

Parameter	Symbol	Value			Unit	Note
		Min.	Typ.	Max.		
LED Light Bar Input Voltage Per Input Pin	VPIN	44.20	50.04	59.4	V	(1), Duty=100%, IPIN=50mA
LED Light Bar Current Per Input Pin	IPIN	---	50	55	mA	(1), (2) Duty=100%
LED Life Time	LLED	30000			Hrs	(3)
Power Consumption	PBL	---	10.008	11.88	W	(1) Duty=100%, IPIN=50mA

Note (1) LED light bar input voltage and current are measured by utilizing a true RMS multimeter as shown below:

Note (2)  $PBL = IPIN \times VPIN \times (4)$  input pins,

Note (3) The lifetime of LED is defined as the time when LED packages continue to operate under the conditions at  $T_a = 25 \pm 2 \text{ }^\circ\text{C}$  and  $I = 50\text{mA}$  (per chip) until the brightness becomes  $\leq 50\%$  of its original value.

Note (4) The module must be operated with constant driving current.

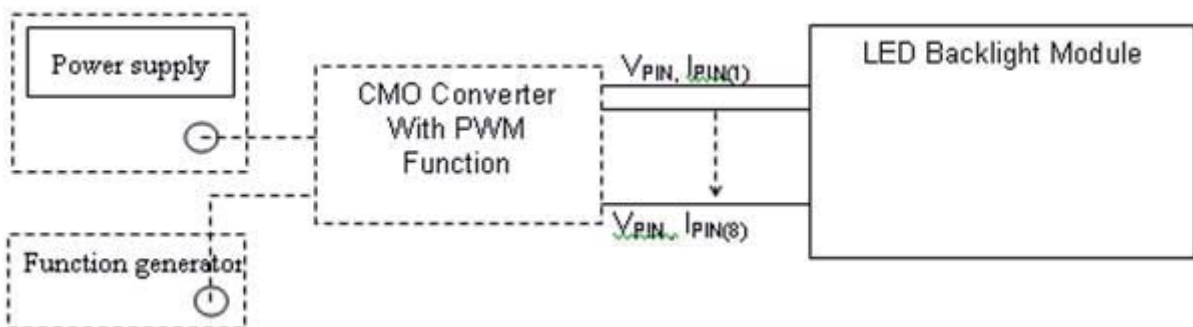

**4.3.4 LIGHTBAR CONNECTOR PIN ASSIGNMENT**

Connector: CI1406M1VL0-NH , CviLux

Top View Dimensions: C ± 0.15, A ± 0.15, 1.76 ± 0.15, .068 ± .006, 5.1, .201, 1.00 ± 0.05, .039 ± .002 TYP., 4.0, .157, B ± 0.25 (4~12P), B' ± 0.25 (2~3P), 4.35 ± 0.25, .171 ± .010, PIN 1, D ± 0.15

Side View Dimensions: .40 ± 0.15, .016 ± .006, 1.75, .069, 4.30 ± 0.15, .130 ± .006

Detail View Dimensions: 3.5, .138, 3.4, .134, 4.85 ± 0.25, .191 ± .010, 1.50, .059, 2.95, .116

**Notes:**

- \* Base: High temperature plastic UL 94V-0, Color Nature
- \* Contact: Copper alloy
- \* Tab: Copper alloy with Matte Tin plated
- \* For Lead Free IR Processes

**Ordering Code:**  
CI14 \*\* M 1 V L 0 - NH  
 ① ② ③ ④ ⑤ ⑥ ⑦ ⑧

① Series No.  
 ② No. of Circuits: 02~12 Pin  
 ③ M= SMT type header  
 ④ Plating: 1= 3.05um(120u") ~ 4.88um(192u")  
 Matte Tin over 1.27um(50u") Nickel  
 ⑤ Type: V= Vertical Type  
 ⑥ Packing Options: L= Latch Type  
 ⑦ Option: 0= Standard  
 ⑧ Other option:  
 -NH= For Lead Free IR Processes and Halogen-Free

DIM. A = 1.00 x NO. OF SPACES  
 DIM. B = DIM. A + 2.70  
 DIM. B' = DIM. A + 2.90  
 DIM. C = DIM. A + 1.50  
 DIM. D = DIM. A + 2.00  
 DIM. E = DIM. A + 2.70  
 \* AVAILABLE IN 2 THROUGH 12

Halogen-Free

Lead Free Process

RoHS Compliant

▲					DATE	UNT: mm / inch	TITLE: 1.00MM(.039")	
▲					DRAWN BY: Karen	11/14-14'	WIRE TO BOARD CONNECTOR	瀚荃股份有限公司 CviLux Corporation
▲					ENGINEER: Karen	11/14-14'	TOLERANCE UNLESS OTHERWISE SPECIFIED	
▲					CHECKED BY: Eislely	11/14-14'	MATERIAL:	
▲					APPROVED BY: Eislely	11/14-14'	CUSTOMER: TCL0124	DRAWING NO. CI14126S1
SYM	NAME	DATE	REVISIONS					PART NO. CI14**M1VL0-NH
								SCALE 6 / 1
								SHEET 1 OF 3

Connector Type	WTB_wafer	位置	尺寸(公差)
工程圖編號	W01	A	0.4±0.25
以INX要求提供工程圖：(範例)		B	3.30±0.15
		C	1.75±0.15
<p style="color: red; font-weight: bold;">① *A ± Tol.</p> <p style="color: red; font-weight: bold;">*B ± Tol.</p> <p style="color: red; font-weight: bold;">(C)</p>			

CN1

Pin number	Description
1	Cathode of LED string
2	Cathode of LED string
3	VLED
4	VLED
5	Cathode of LED string
6	Cathode of LED string

Note(1) Connector(wire type): CviLux(CI1406M1VL0-NH) or equivalent.

Note(2) User' s mating connector part No.: FCN(WF1300106-B) or CviLux(CI1406SL000-NH) and hook width must be less than 4.5mm.

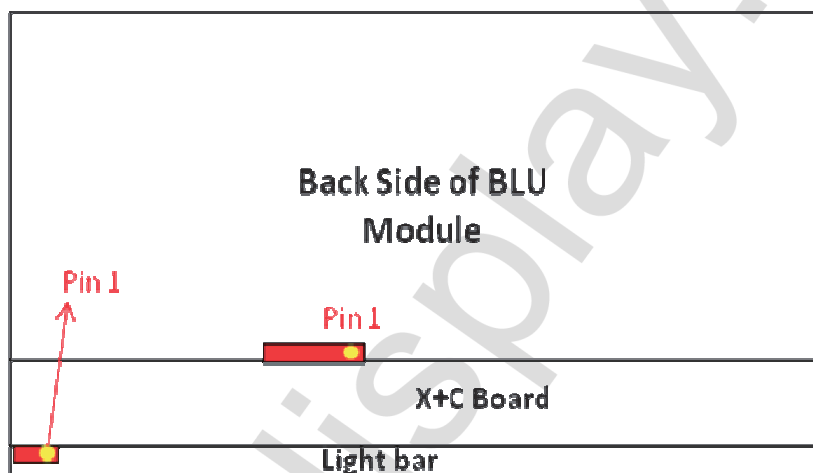

## 4.4 LVDS INPUT SIGNAL SPECIFICATIONS

### 4.4.1 LVDS DATA MAPPING TABLE

LVDS Channel O0	LVDS output	D7	D6	D4	D3	D2	D1	D0
	Data order	OG0	OR5	OR4	OR3	OR2	OR1	OR0
LVDS Channel O1	LVDS output	D18	D15	D14	D13	D12	D9	D8
	Data order	OB1	OB0	OG5	OG4	OG3	OG2	OG1
LVDS Channel O2	LVDS output	D26	D25	D24	D22	D21	D20	D19
	Data order	DE	NA	NA	OB5	OB4	OB3	OB2
LVDS Channel O3	LVDS output	D23	D17	D16	D11	D10	D5	D27
	Data order	NA	OB7	OB6	OG7	OG6	OR7	OR6
LVDS Channel E0	LVDS output	D7	D6	D4	D3	D2	D1	D0
	Data order	EG0	ER5	ER4	ER3	ER2	ER1	ER0
LVDS Channel E1	LVDS output	D18	D15	D14	D13	D12	D9	D8
	Data order	EB1	EB0	EG5	EG4	EG3	EG2	EG1
LVDS Channel E2	LVDS output	D26	D25	D24	D22	D21	D20	D19
	Data order	DE	NA	NA	EB5	EB4	EB3	EB2
LVDS Channel E3	LVDS output	D23	D17	D16	D11	D10	D5	D27
	Data order	NA	EB7	EB6	EG7	EG6	ER7	ER6

#### 4.4.2 COLOR DATA INPUT ASSIGNMENT

The brightness of each primary color (red, green and blue) is based on the 8-bit gray scale data input for the color. The higher the binary input, the brighter the color. The table below provides the assignment of color versus data input.

Color		Data Signal																							
		Red								Green								Blue							
		R7	R6	R5	R4	R3	R2	R1	R0	G7	G6	G5	G4	G3	G2	G1	G0	B7	B6	B5	B4	B3	B2	B1	B0
Basic Colors	Black	0	0	0	0	0	0	0	0	0	0	0	0	0	0	0	0	0	0	0	0	0	0	0	0
	Red	1	1	1	1	1	1	1	1	0	0	0	0	0	0	0	0	0	0	0	0	0	0	0	0
	Green	0	0	0	0	0	0	0	0	1	1	1	1	1	1	1	1	0	0	0	0	0	0	0	0
	Blue	0	0	0	0	0	0	0	0	0	0	0	0	0	0	0	0	1	1	1	1	1	1	1	1
	Cyan	0	0	0	0	0	0	0	0	1	1	1	1	1	1	1	1	1	1	1	1	1	1	1	1
	Magenta	1	1	1	1	1	1	1	1	0	0	0	0	0	0	0	0	1	1	1	1	1	1	1	1
	Yellow	1	1	1	1	1	1	1	1	1	1	1	1	1	1	1	1	0	0	0	0	0	0	0	0
	White	1	1	1	1	1	1	1	1	1	1	1	1	1	1	1	1	1	1	1	1	1	1	1	1
Gray Scale Of Red	Red(0) / Dark	0	0	0	0	0	0	0	0	0	0	0	0	0	0	0	0	0	0	0	0	0	0	0	
	Red(1)	0	0	0	0	0	0	0	1	0	0	0	0	0	0	0	0	0	0	0	0	0	0	0	
	Red(2)	0	0	0	0	0	0	1	0	0	0	0	0	0	0	0	0	0	0	0	0	0	0	0	
	⋮	⋮	⋮	⋮	⋮	⋮	⋮	⋮	⋮	⋮	⋮	⋮	⋮	⋮	⋮	⋮	⋮	⋮	⋮	⋮	⋮	⋮	⋮	⋮	
	⋮	⋮	⋮	⋮	⋮	⋮	⋮	⋮	⋮	⋮	⋮	⋮	⋮	⋮	⋮	⋮	⋮	⋮	⋮	⋮	⋮	⋮	⋮	⋮	
	Red(253)	1	1	1	1	1	1	0	1	0	0	0	0	0	0	0	0	0	0	0	0	0	0	0	
	Red(254)	1	1	1	1	1	1	1	0	0	0	0	0	0	0	0	0	0	0	0	0	0	0	0	
	Red(255)	1	1	1	1	1	1	1	1	0	0	0	0	0	0	0	0	0	0	0	0	0	0	0	
Gray Scale Of Green	Green(0) / Dark	0	0	0	0	0	0	0	0	0	0	0	0	0	0	0	0	0	0	0	0	0	0	0	
	Green(1)	0	0	0	0	0	0	0	0	0	0	0	0	0	0	0	1	0	0	0	0	0	0	0	
	Green(2)	0	0	0	0	0	0	0	0	0	0	0	0	0	0	1	0	0	0	0	0	0	0	0	
	⋮	⋮	⋮	⋮	⋮	⋮	⋮	⋮	⋮	⋮	⋮	⋮	⋮	⋮	⋮	⋮	⋮	⋮	⋮	⋮	⋮	⋮	⋮	⋮	
	⋮	⋮	⋮	⋮	⋮	⋮	⋮	⋮	⋮	⋮	⋮	⋮	⋮	⋮	⋮	⋮	⋮	⋮	⋮	⋮	⋮	⋮	⋮	⋮	
	Green(253)	0	0	0	0	0	0	0	0	1	1	1	1	1	1	0	1	0	0	0	0	0	0	0	
	Green(254)	0	0	0	0	0	0	0	0	1	1	1	1	1	1	1	0	0	0	0	0	0	0	0	
	Green(255)	0	0	0	0	0	0	0	0	1	1	1	1	1	1	1	1	0	0	0	0	0	0	0	
Gray Scale Of Blue	Blue(0) / Dark	0	0	0	0	0	0	0	0	0	0	0	0	0	0	0	0	0	0	0	0	0	0	0	
	Blue(1)	0	0	0	0	0	0	0	0	0	0	0	0	0	0	0	0	0	0	0	0	0	0	1	
	Blue(2)	0	0	0	0	0	0	0	0	0	0	0	0	0	0	0	0	0	0	0	0	0	0	1	
	⋮	⋮	⋮	⋮	⋮	⋮	⋮	⋮	⋮	⋮	⋮	⋮	⋮	⋮	⋮	⋮	⋮	⋮	⋮	⋮	⋮	⋮	⋮	⋮	
	⋮	⋮	⋮	⋮	⋮	⋮	⋮	⋮	⋮	⋮	⋮	⋮	⋮	⋮	⋮	⋮	⋮	⋮	⋮	⋮	⋮	⋮	⋮	⋮	
	Blue(253)	0	0	0	0	0	0	0	0	0	0	0	0	0	0	0	1	1	1	1	1	1	1	0	
	Blue(254)	0	0	0	0	0	0	0	0	0	0	0	0	0	0	0	1	1	1	1	1	1	1	0	
	Blue(255)	0	0	0	0	0	0	0	0	0	0	0	0	0	0	0	1	1	1	1	1	1	1	1	

Note (1) 0: Low Level Voltage, 1: High Level Voltage



#### 4.5 DISPLAY TIMING SPECIFICATIONS

The input signal timing specifications are shown as the following table and timing diagram.

Signal	Item	Symbol	Min.	Typ.	Max.	Unit	Note
LVDS Clock	Frequency	Fc	57.5	74.25	97.98	MHz	
	Period	Tc	-	13.47		ns	
	Input cycle to cycle jitter	T <sub>rcj</sub>	-0.02*TC	-	0.02*TC	ns	(1)
	Input Clock to data skew	TLVCCS	-0.02*TC		0.02*TC		(2)
	Spread spectrum modulation range	F <sub>clk_in_mod</sub>	0.97*FC	-	1.03*FC	MHz	(3)
	Spread spectrum modulation frequency	F <sub>SSM</sub>	-	-	100	KHz	
Vertical Display Term	Frame Rate	Fr	49	60	77	Hz	
	Total	Tv	1110	1125	1251	Th	Tv=Tvd+Tvb-
	Active Display	Tvd	1080	1080	1080	Th	-
Horizontal Display Term	Blank	Tvb	Tv-Tvd	Tv-Tvd	Tv-Tvd	Th	(4)
	Total	Th	1050	1100	1150	Tc	Th=Thd+Thb
	Active Display	Thd	960	960	960	Tc	-
Horizontal Display Term	Blank	Thb	Th-Thd	Th-Thd	Th-Thd	Tc	-

Note: Because this module is operated by DE only mode, Hsync and Vsync input signals are ignored.

$$F_c = F_r \times T_v \times T_h$$

Please make sure the range of pixel clock has follow the below equation and Fc, Fr, Tv, Th not allowed to get beyond the min or max spec.

#### INPUT SIGNAL TIMING DIAGRAM

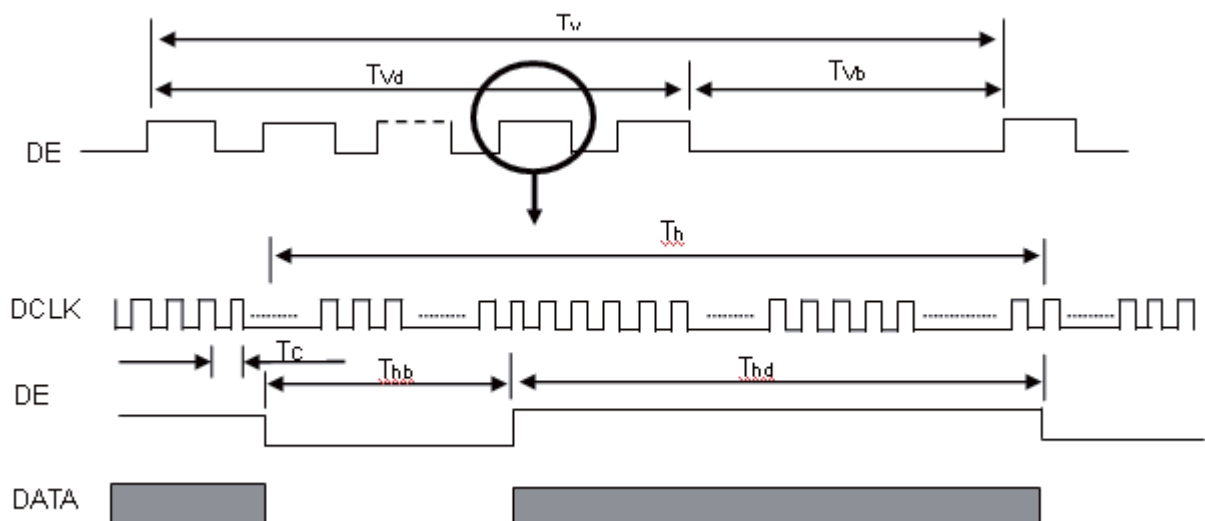

Note (1) The input clock cycle-to-cycle jitter is defined as below figures.  $Trcl = |T_1 - T_1'|$

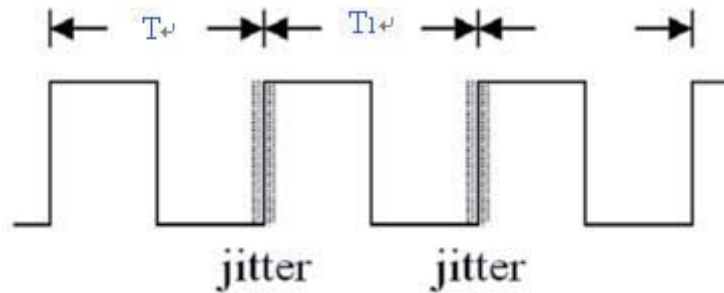

Note (2) Input Clock to data skew is defined as below figures.

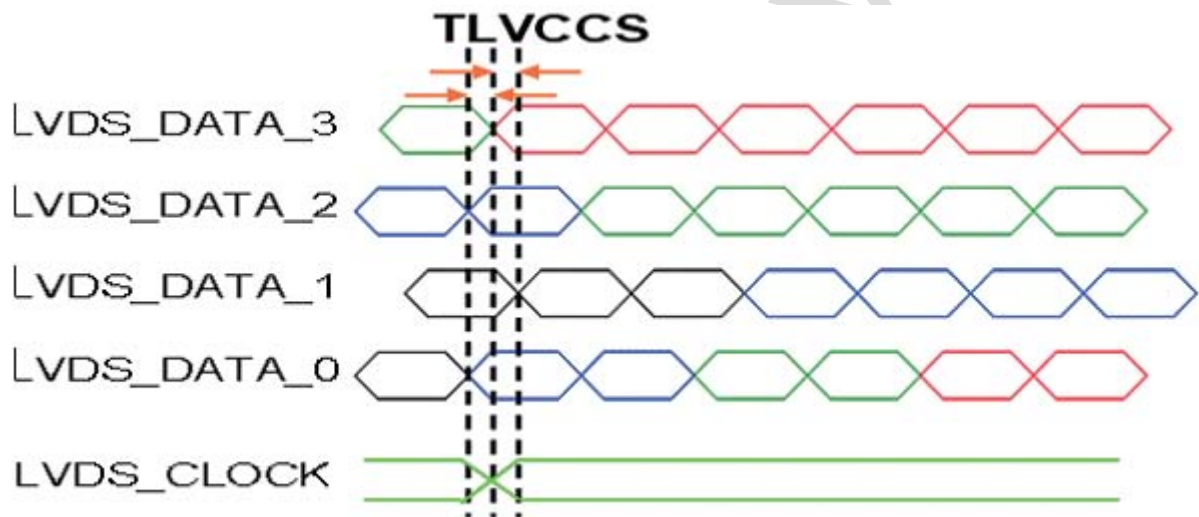

Note (3) The SSCG (Spread spectrum clock generator) is defined as below figures.

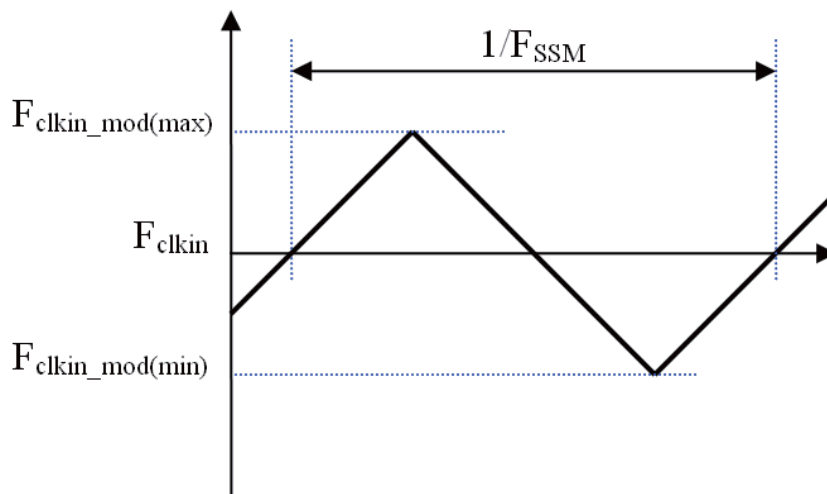

Note (4) The DCLK range at last line of V-blank should be set in 0 to Hdisplay/2

#### 4.6 POWER ON/OFF SEQUENCE

The power sequence specifications are shown as the following table and diagram.

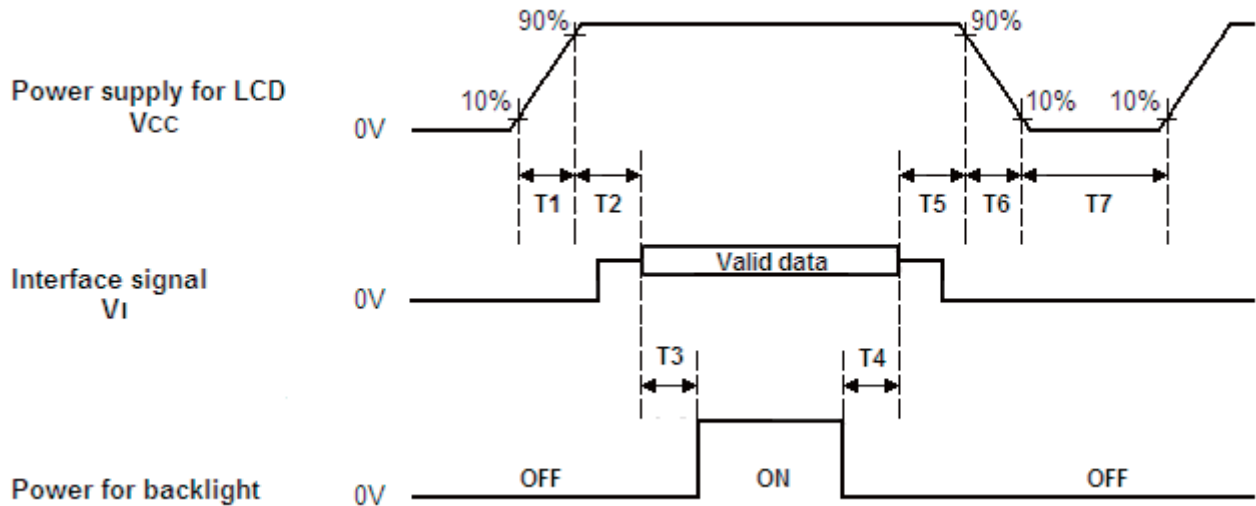

Timing Specifications:

Parameters	Values			Units	Note
	Min	Typ.	Max		
T1	0.5	--	10	ms	
T2	0	30	50	ms	
T3	450	--	--	ms	
T4	100	250	--	ms	(2)
T5	0	20	50	ms	
T6	0.1	--	100	ms	(7)
T7	1000	--	--	ms	(4)

Note (1) The supply voltage of the external system for the module input should be the same as the definition of Vcc.

Note (2) When the backlight turns on before the LCD operation of the LCD turns off, the display may momentarily become abnormal screen and it will be no reliability concern(T4<100ms).

Note (3) In case of VCC = off level, please keep the level of input signals on the low or keep a high impedance.

Note (4) T7 should be measured after the module has been fully discharged between power off and on period.

Note (5) Interface signal shall not be kept at high impedance when the power is on.

Note (6) INX won't take any responsibility for the products which are damaged by the customers not following the Power Sequence.

Note (7) There might be slight electronic noise when LCD is turned off (even backlight unit is also off). To avoid this symptom, we suggest "Vcc falling timing" to follow "t6 spec".

## 5. OPTICAL CHARACTERISTICS

### 5.1 TEST CONDITIONS

Item	Symbol	Value	Unit
Ambient Temperature	Ta	25±2	°C
Ambient Humidity	Ha	50±10	%RH
Supply Voltage	V <sub>CC</sub>	5	V
Input Signal	According to typical value in "3. ELECTRICAL CHARACTERISTICS"		
LED Light Bar Input Current Per Input Pin	I <sub>PIN</sub>	50 ± 1.2	mA <sub>DC</sub>
PWM Duty Ratio	D	100	%
LED Light Bar Test Converter	INX 27-D041745		

### 5.2 OPTICAL SPECIFICATIONS

The relative measurement methods of optical characteristics are shown in 5.2. The following items should be measured under the test conditions described in 5.1 and stable environment shown in Note (5).

Item	Symbol	Condition	Min.	Typ.	Max.	Unit	Note	
Color Chromaticity (CIE 1931)	Red	Rx	$\theta_x=0^\circ, \theta_y=0^\circ$ CS-2000 R=G=B=255 Gray scale	Typ - 0.03	0.650	Typ + 0.03	-	(1), (5)
		Ry			0.339			
	Green	Gx			0.324			
		Gy			0.613			
	Blue	Bx			0.157			
		By			0.049			
	White	Wx			0.313			
		Wy			0.329			
Center Luminance of White (Center of Screen)	L <sub>c</sub>		200	250	-	cd/m <sup>2</sup>	(4), (5)	
Contrast Ratio	CR		---	1000	-	-	(2), (5)	
Response Time	T <sub>R</sub>	$\theta_x=0^\circ, \theta_y=0^\circ$	---	8	---	ms	(3)	
	T <sub>F</sub>			7				
White Variation	W	$\theta_x=0^\circ, \theta_y=0^\circ$	75	---	---	%	(5), (6)	
Viewing Angle	Horizontal	$\theta_{x-} + \theta_{x+}$	CR ≥ 10	170	178	---	Deg.	(1), (5)
	Vertical	$\theta_{y-} + \theta_{y+}$		170	178			
Viewing Angle	Horizontal	$\theta_{x-} + \theta_{x+}$	CR ≥ 5	170	178	---	Deg.	(1), (5)
	Vertical	$\theta_{y-} + \theta_{y+}$		170	178			

Note (1) Definition of Viewing Angle ( $\theta_x$ ,  $\theta_y$ ):

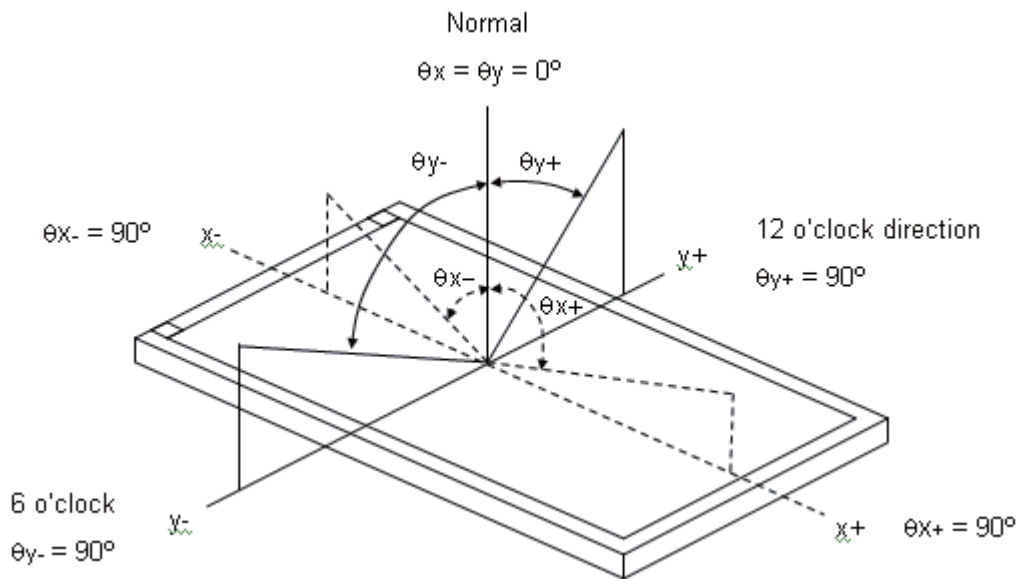

Note (2) Definition of Contrast Ratio (CR):

The contrast ratio can be calculated by the following expression.

$$\text{Contrast Ratio (CR)} = L_{255} / L_0$$

L255: Luminance of gray level 255

L 0: Luminance of gray level 0

$$\text{CR} = \text{CR} (5)$$

CR (X) is corresponding to the Contrast Ratio of the point X at Figure in Note (6).

Note (3) Definition of Response Time ( $T_R$ ,  $T_F$ ):

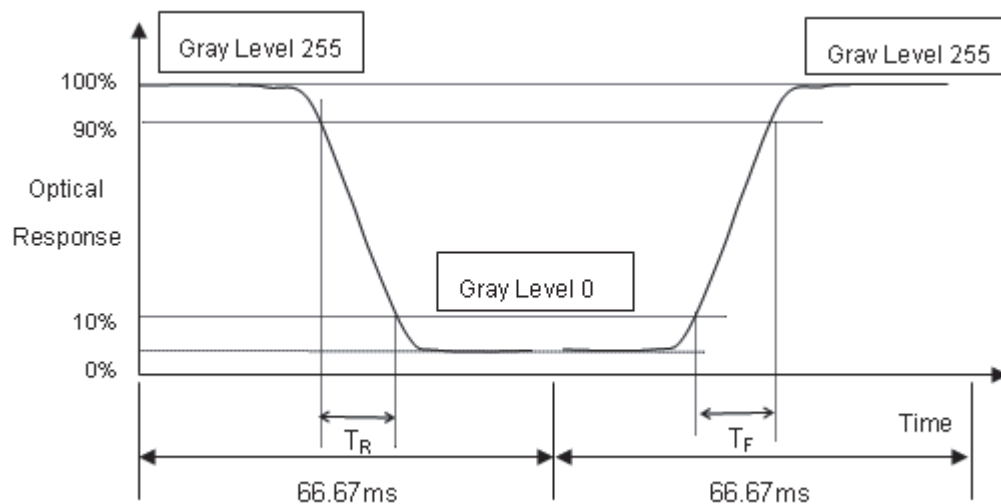

Note (4) Definition of Luminance of White ( $L_c$ ):

Measure the luminance of gray level 255 at center point

$$L_c = L(5)$$

$L(x)$  is corresponding to the luminance of the point X at Figure in Note (6).

Note (5) Measurement Setup:

The LCD module should be stabilized at given temperature for 40 minutes to avoid abrupt temperature change during measuring. In order to stabilize the luminance, the measurement should be executed after lighting Backlight for 40 minutes in a windless room.

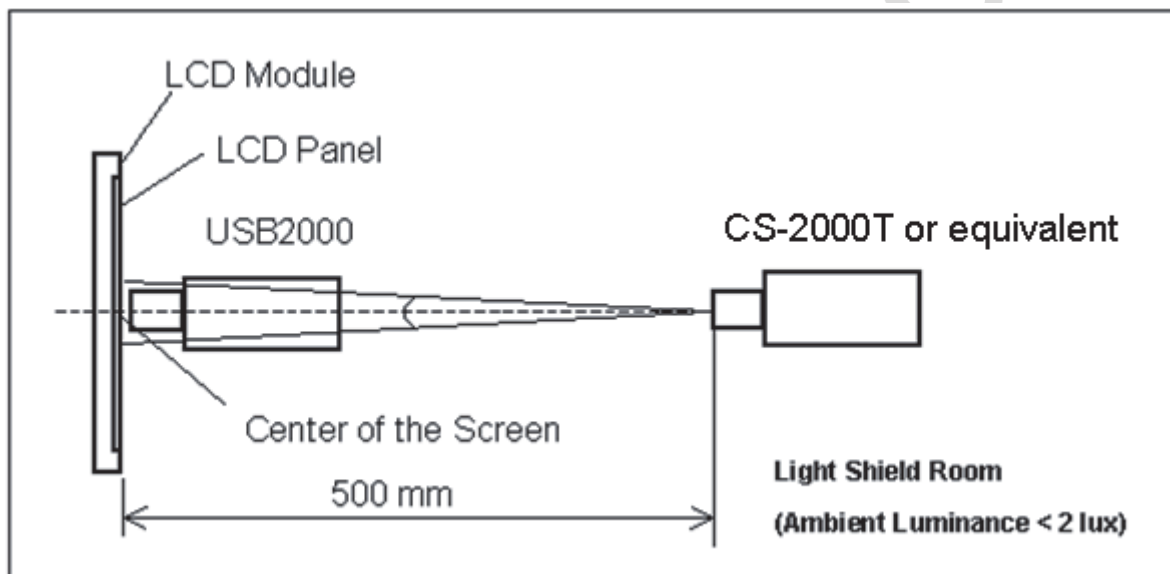

Note (6) Definition of White Variation ( $\delta W$ ):

Measure the luminance of gray level 255 at 9 points

$$\delta W = ( \text{Minimum } [L(1) \sim L(9)] / \text{Maximum } [L(1) \sim L(9)] ) * 100\%$$

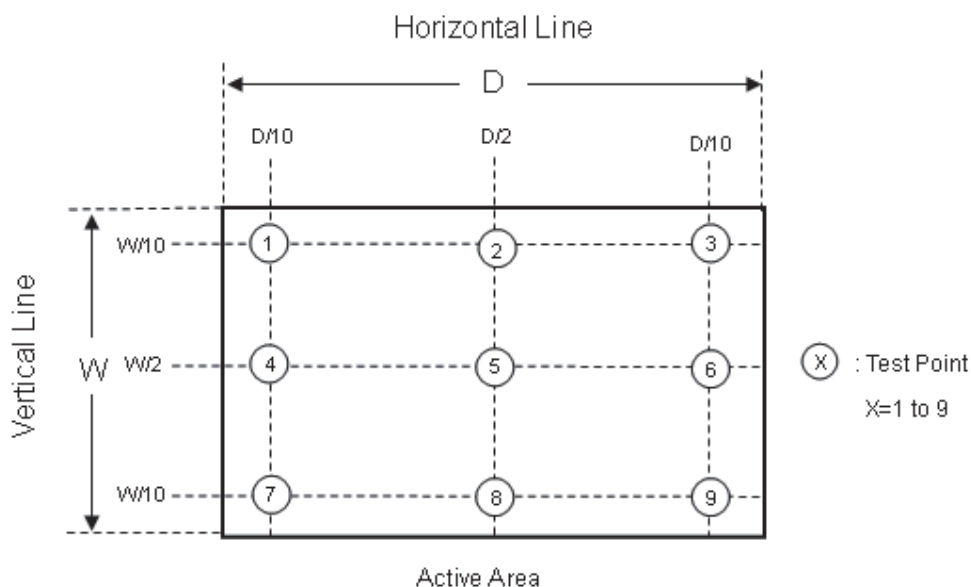

**6. RELIABILITY TEST ITEM**

Items	Required Condition	Note
Temperature Humidity Bias (THB)	Ta= 50°C , 80%RH, 240hours	
High Temperature Operation (HTO)	Ta= 50°C , 240hours	
Low Temperature Operation (LTO)	Ta= 0°C , 240hours	
High Temperature Storage (HTS)	Ta= 60°C , 240hours	
Low Temperature Storage (LTS)	Ta= -20°C , 240hours	
Vibration Test (Non-operation)	Acceleration: 1.5 G Wave: sine Frequency: 10 - 300 Hz Sweep: 30 Minutes each Axis (X, Y, Z)	
Shock Test (Non-operation)	Acceleration: 50 G Wave: Half-sine Active Time: 11 ms Direction : ± X, ± Y, ± Z.(one time for each Axis)	
Thermal Shock Test (TST)	-20°C/30min , 60°C / 30min , 100 cycles	
On/Off Test	25°C , On/10sec , Off /10sec , 30,000 cycles	
ESD (Electro Static Discharge)	Contact Discharge: ± 8KV, 150pF(330Ω)	
	Air Discharge: ± 15KV, 150pF(330Ω)	
Altitude Test	Operation: 50°C , 16,400 ft / 8H	
	Non-Operation: 25°C 40,000 ft / 16H	

Note (1) criteria : Normal display image with no obvious non-uniformity and no line defect.

Note (2) Evaluation should be tested after storage at room temperature for more than two hour

Note (3) At testing Vibration and Shock, the fixture in holding the module has to be hard and rigid enough so that the module would not be twisted or bent by the fixture.

The fixing condition is shown as below:

At Room Temperature

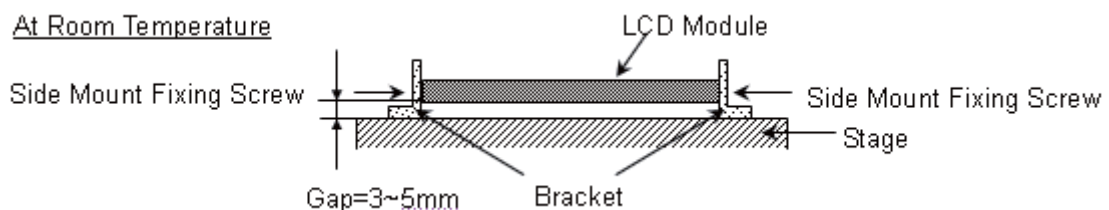

## 7. MECHANICAL STRENGTH CHARACTERISTICS

### 7.1 MECHANICAL STRENGTH SPECIFICATIONS

Item	Condition	Min	Unit	Note
Mechanical Strength	128 <sup>th</sup> Gray Pattern	0.6	Kgf	

### 7.2 TEST CONDITIONS

Items	Description
Test Condition	1. Ambient Illumination : 10~15 lux 2. Test Pattern : 128 Gray 3. Distance of the judgment : 30cm from the surface of module 4. Viewing angle of the judgment : Front
Gage Information	1. Push pull guage a. Model name : HF-50, maker : ALGOL b. Shape of gage tip - Diameter : 2mm - Thickness : 2mm
Definition of Minimum force	To measure minimum force when operator detects any white spot and light leakage that have occurred while operator presses on back side of module with push pull gage.

### 7.3 DEFINITION OF TEST POINTS

Measure the minimum force of test points at 128th Gray pattern. The test points at back side of module area is showing as below (except PCBA).

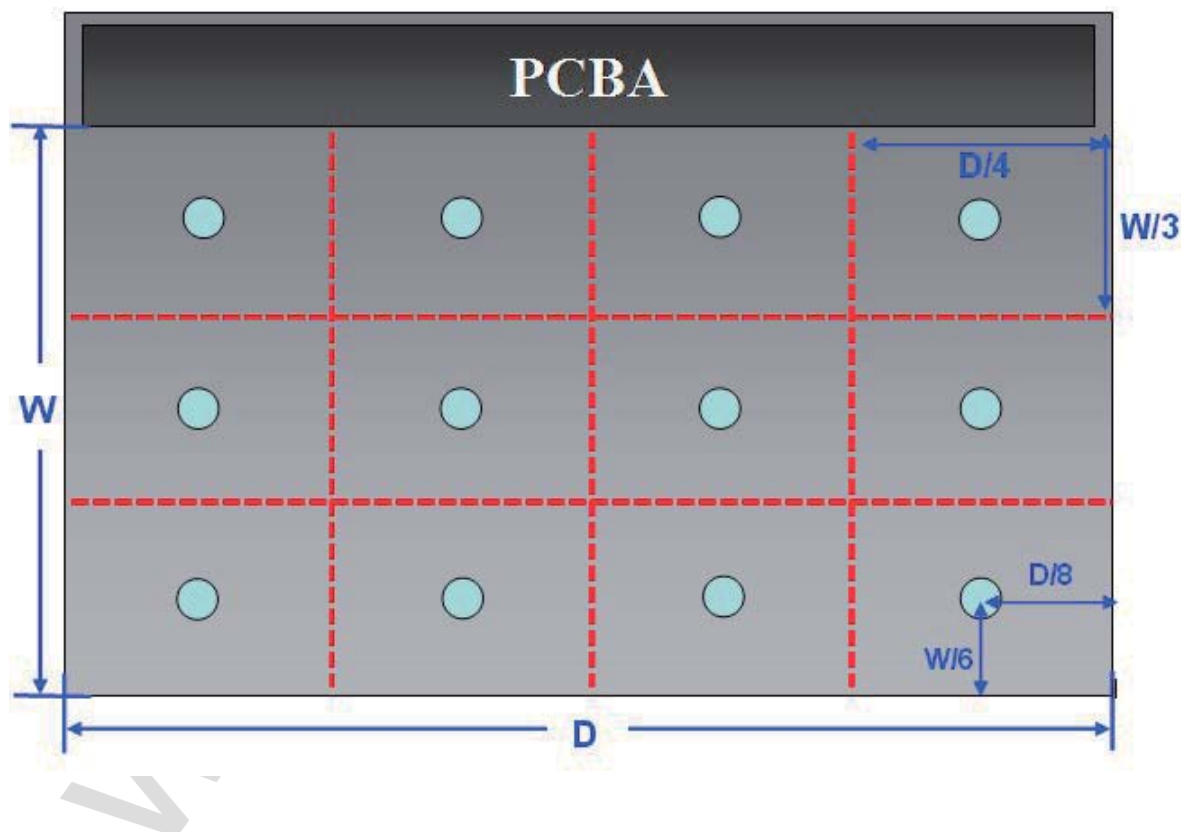



**8. PACKING**

**8.1 PACKING SPECIFICATIONS**

- (1) 10 LCD modules / 1 Box
- (2) Box dimensions: 567(L) X 301(W) X 376(H) mm
- (3) Weight: approximately: 20.1kg (10 modules per box)

**8.2 PACKING METHOD**

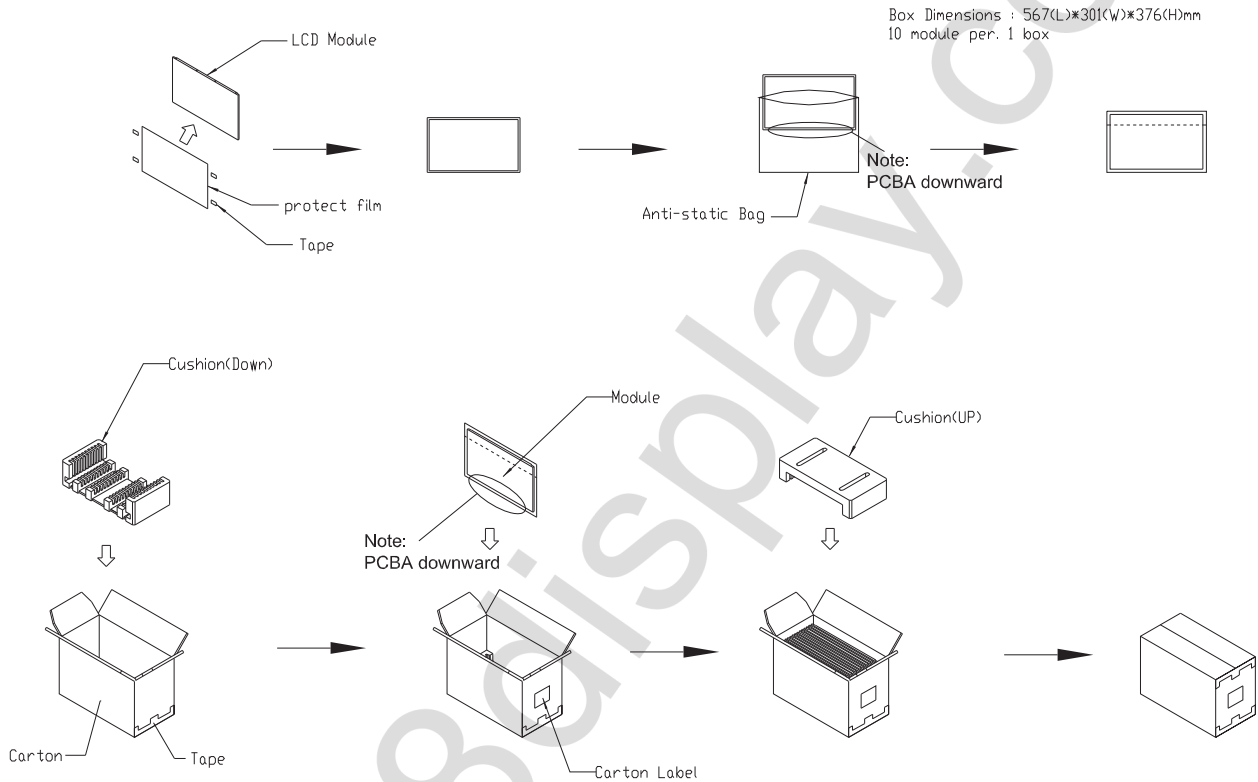

**Figure. 8-1 Packing method**

8.3 PALLET

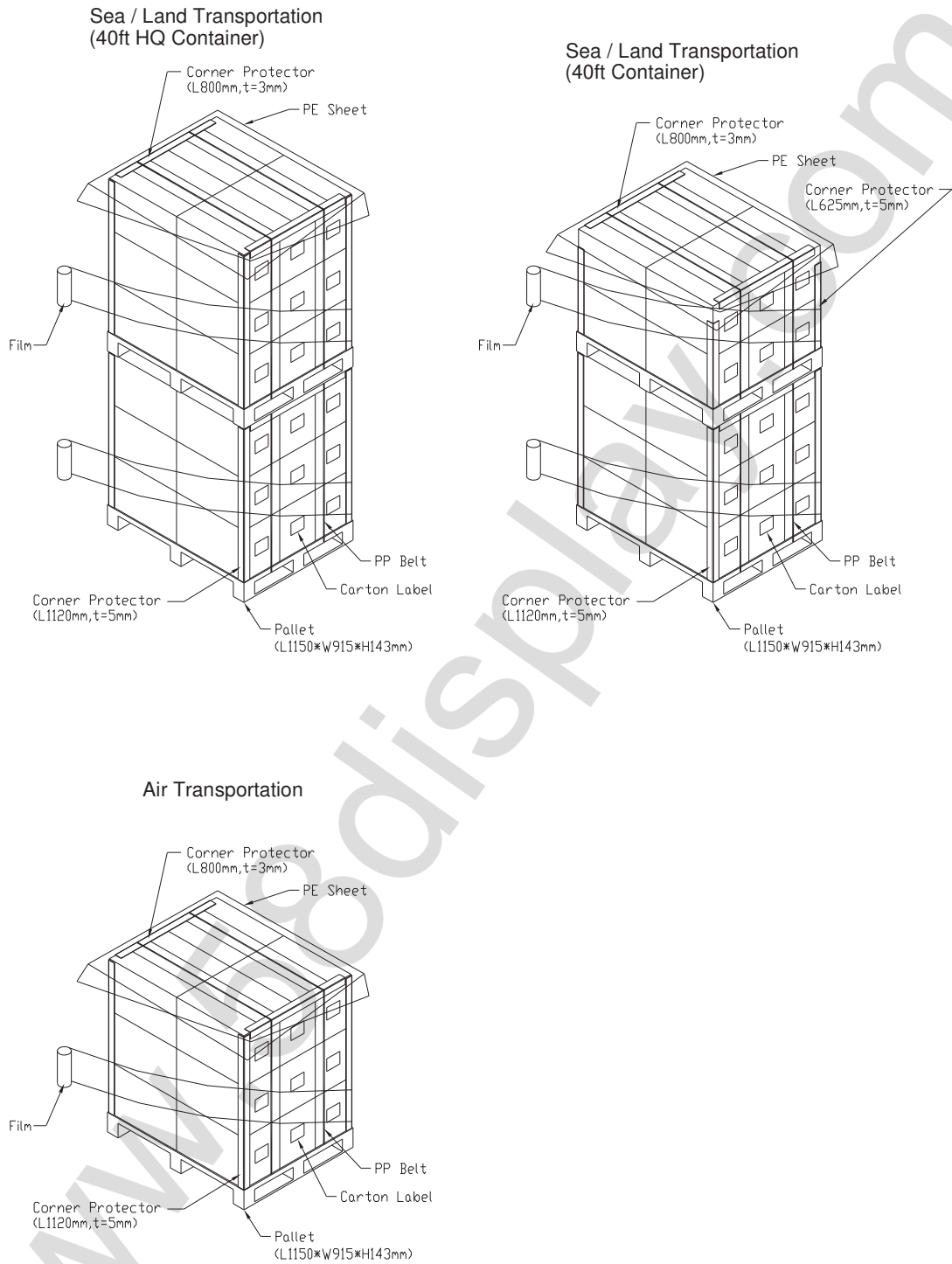
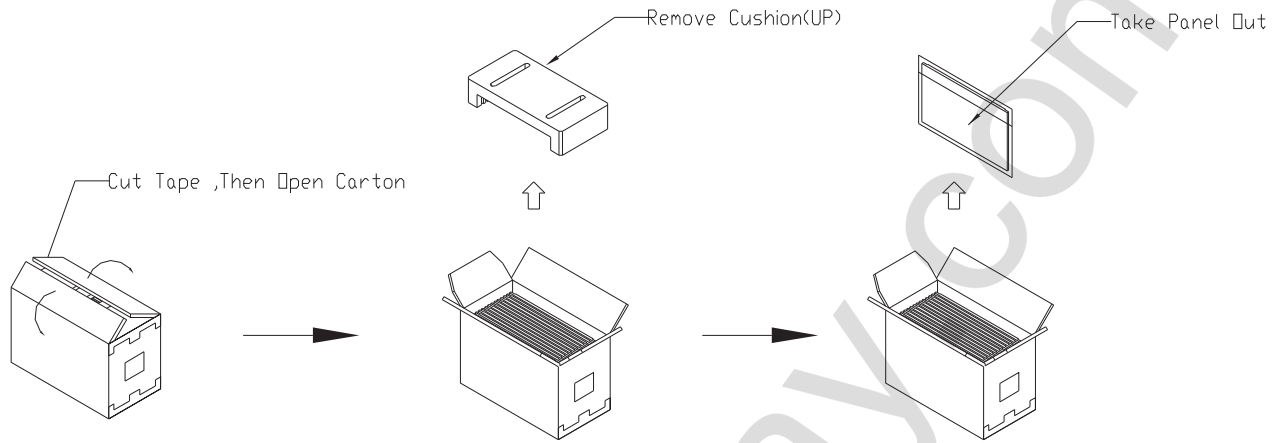

Figure. 8-2 Packing method

### 8.4 UN-PACKING METHOD

UN-packaging method is shown as following figures.



**Figure. 8-3 Un-packing method**

## 9. INX MODULE LABEL

The barcode nameplate is pasted on each module as illustration, and its definitions are as following explanation.



(a) Model Name: M215HCJ-L3N

(b) Revision: Rev. XX, for example: A0, A1... B1, B2... or C1, C2...etc.

(c) INX barcode definition:

Serial ID: XX-XX-X-XX-YMD-L-NNNN

Code	Meaning	Description
XX	INX internal use	-
XX	Revision	Cover all the change
X	INX internal use	-
XX	INX internal use	-
YMD	Year, month, day	Year: 0~9, 2001=1, 2002=2, 2011=1, 2012=2... Month: 1~12=1, 2, 3, ~, 9, A, B, C Day: 1~9, 11~31, A, ~, Y
L	Product line #	Line 1=1, Line 2=2, Line 3=3, ...
NNNN	Serial number	Manufacturing sequence of product

(d) Customer's barcode definition:

Serial ID: CN- XXXXXX-XXXXX-YMD-L-NNN

Code	Meaning	Description
CN	Country	CN= China
XXXXXX	Dell PN	M215HCJ-L3N= YMCPK
XXXXX	Location Regent	IN200:NINGBO(寧波),INF00:NANHAI(南海)
YMD	Year, month, day	Year: 0~9, 2001=1, 2002=2, 2011=1, 2012=2... Month: 1~12=1, 2, 3, ~, 9, A, B, C Day: 1~31=1,2,3,~9,A,B,C ~V
L	Factory code	Eg :Ningbo A= A ; Ningbo B=B
NNN	Serial number	By LCD supplier

(e) FAB ID(UL Factory ID):

Region	Factory ID
TWINX	GEMN
NBINX	VIRO
NBINX	CANO
NHINX	CAPG

## 10. PRECAUTIONS

### 10.1 ASSEMBLY AND HANDLING PRECAUTIONS

- (1) Do not apply rough force such as bending or twisting to the module during assembly.
- (2) To assemble or install module into user's system can be only in clean working areas. The dust and oil may cause electrical short or worsen the polarizer.
- (3) It's not permitted to have pressure or impulse on the module because the LCD panel and Backlight will be damaged.
- (4) Always follow the correct power sequence when LCD module is connecting and operating.
- (5) Do not pull the I/F connector in or out while the module is operating.
- (6) Do not disassemble the module.
- (7) Use a soft dry cloth without chemicals for cleaning, because the surface of polarizer is very soft and easily scratched.
- (8) It is dangerous that moisture come into or contacted the LCD module, because moisture may damage LCD module when it is operating.
- (9) High temperature or humidity may reduce the performance of module. Please store LCD module within the specified storage conditions.
- (10) When ambient temperature is lower than 10°C may reduce the display quality. For example, the response time will become slowly.

### 10.2 STORAGE PRECAUTIONS

- (1) Do not leave the module in high temperature, and high humidity for a long time. It is highly recommended to store the module with temperature from 0°C to 35°C and relative humidity of less than 90%
- (2) Do not store the TFT – LCD module in direct sunlight
- (3) The module should be stored in dark place. It is prohibited to apply sunlight or fluorescent light in storing

### 10.3 OPERATION PRECAUTIONS

(1) The LCD product should be operated under normal condition.

Normal condition is defined as below :

Temperature :  $20\pm 15^{\circ}\text{C}$

Humidity:  $65\pm 20\%$

Display pattern : continually changing pattern(Not stationary)

(2) If the product will be used in extreme conditions such as high temperature,high humidity,high altitude ,display pattern or operation time etc...It is strongly recommended to contact INX for application engineering advice . Otherwise , Its reliability and function may not be guaranteed.

### 10.4 SAFETY PRECAUTIONS

(1) If the liquid crystal material leaks from the panel, it should be kept away from the eyes or mouth. In case of contact with hands, skin or clothes, it has to be washed away thoroughly with soap.

(2) After the module's end of life, it is not harmful in case of normal operation and storage.

### 10.5 SAFETY STANDARDS

The LCD module should be certified with safety regulations as follows:





(1) UL60950-1 or updated standard.

(2) IEC60950-1 or updated standard.

### 10.6 OTHER

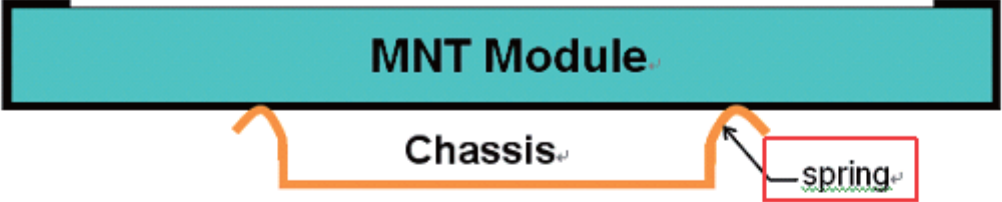
When fixed patterns are displayed for a long time, remnant image is likely to occur.

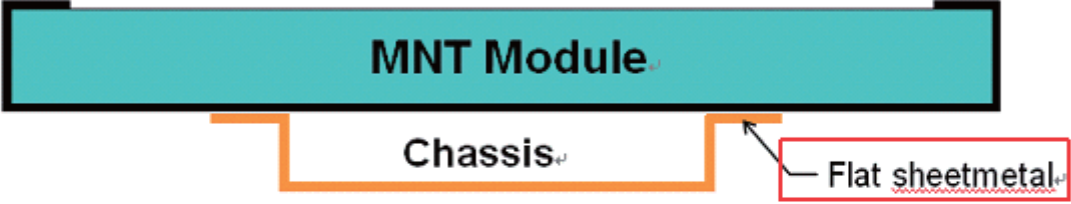
## Appendix 1. SYSTEM COVER DESIGN NOTICE

1.	Set Chassis and MNT Module touching Mode
	
	
	
Definition	<p>a) To prevent from abnormal display &amp; white spot after Mechanical test, it is not recommended to used spring type chassis.</p> <p>b) We suggest the contact mode between Chassis and Module rear cover is Tape/Sponge, second is Flat sheetmetal type chassis (Don't interference from flat sheetmetal of chassis to rear cover of Module).</p>

2	Tape/sponge design on system inner surface
<p>The diagram illustrates the correct placement of Tape/Sponge on the system inner surface. The top part shows a cross-section of the MNT Module, Chassis, and System rear bezel. The Tape/Sponge is placed between the chassis and the module. Below are two top-down views: the first, marked with a red 'X', shows four separate pieces of Tape/Sponge at the corners; the second, marked with a blue circle, shows a single rectangular piece of Tape/Sponge covering the entire area between the chassis and the module.</p>	
Definition	<p>a) To prevent from abnormal display &amp; white spot after Mechanical test, We suggest using Tape/Sponge as medium between chassis and Module rear cover could reduce the occurrence of white spot.</p> <p>b) When using the Tape/Sponge, suggest it be lay over between set chassis and module rear cover. it is not recommended to add tape/sponge in separate location. Since each tape/sponge may act as pressure concentration location.</p>



3	<b>System inner surface examination</b>
<p>The diagram illustrates the system inner surface examination. It shows a top-down view of a blue system cover with a purple hatched area at the bottom. Below it is a teal 'MNT Module'. The bottom part is a cross-section showing the 'System cover inner surface' (teal), 'Burr' (orange), 'Chassis' (orange), 'PCB' (green), and 'Step' (teal).</p>	
Definition	<p>a). Burr at logo edge, step, protrusion or PCB board will easily cause white spot.</p> <p>b). Keeping flat surface underneath module is recommended.</p> <p>c). The area (  ) on Module PCBA and Light bar connector should keep at least 1mm gap to any structure with System cover inner surface.</p>

4	<b>The overlapping part on System's Chassis and electric wire needs gap structure.</b>
<p>The diagrams illustrate the required gap structure. The A-A section shows the FFC electric overlapping the chassis. The B-B section shows the electric wire overlapping the chassis. The top view shows the chassis with the module, LVDS CNT, Light Bar CNT, FPC, and wire, highlighting the need for a gap between the chassis and the wire.</p>	
Definition	The overlapping part structure to avoid display of white spot by pressing overlapping part cause interference.

5	<b>System cover's ventilation outlet structure</b>
<p>The diagram shows the system cover with the module and light source edge (LED). It indicates the location of the light source connector and the ventilation outlet structure on the lith source side of the module.</p>	
Definition	To prevent from accidental display bright leakage, the edge of the set ventilation outlet structure on side of Module Light bar in system cover inner surface.

**Appendix 2. OUTLINE DRAWING**

1 2 3 4 5 6 7 8 9 10 11 12 13 14 15 16

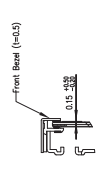

SECTION X-Y  
SCALE 2:1

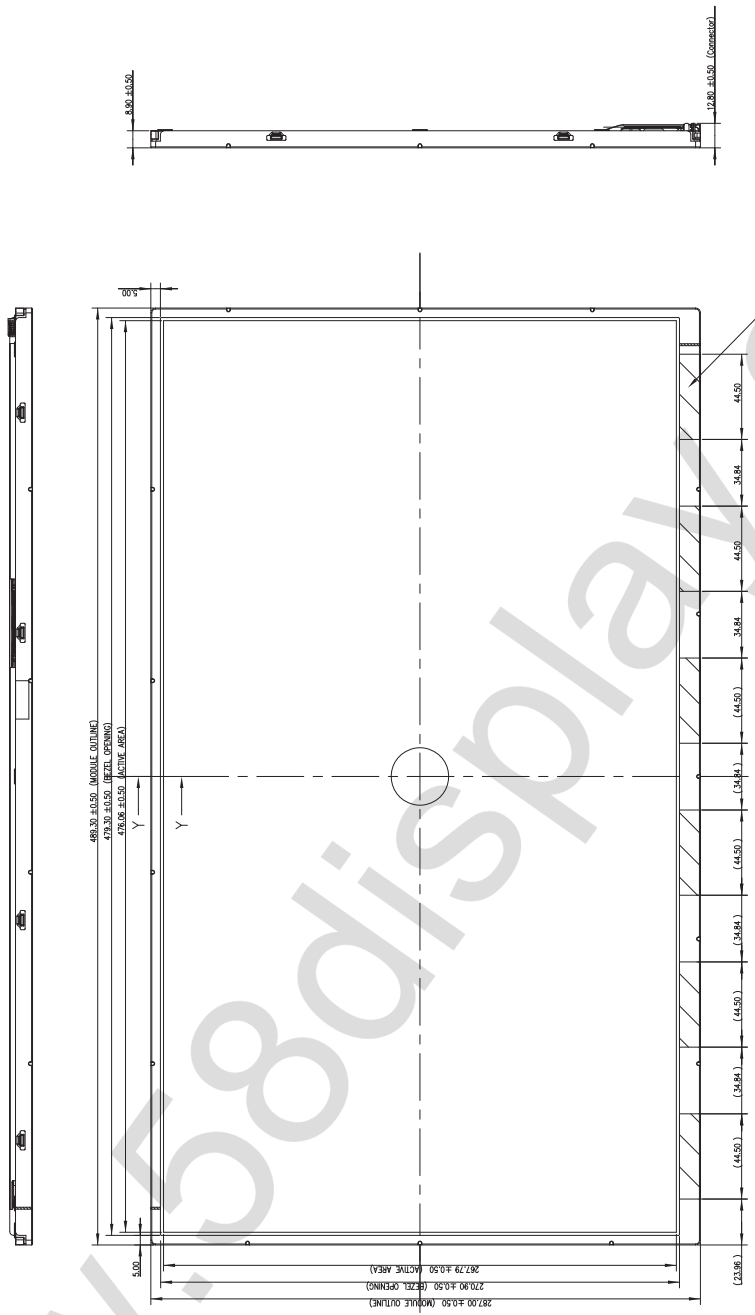

NOTE: DO NOT CUT OFF THE BEZEL TOGETHER WITH THE MOUNTING STRIP AND WELD POINT BEHIND THE POSITIONS OF DATA COR

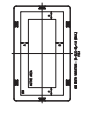

- NOTE: BEFORE PROCEEDING WITH PRODUCTION:
1. THE DISPLAY MODULES SHOULD BE PROTECTED BY AN ANTI-STATIC BAG.
  2. THE DISPLAY MODULES SHOULD BE STORED IN A DRY PLACE.
  3. THE DISPLAY MODULES SHOULD BE STORED IN A DRY PLACE.
  4. THE DISPLAY MODULES SHOULD BE STORED IN A DRY PLACE.
  5. THE DISPLAY MODULES SHOULD BE STORED IN A DRY PLACE.
  6. Display area position tolerance:  $\pm 0.15$  mm

Rev.	Date	By	Check	Appr.
01				
02				
03				
04				
05				
06				
07				
08				
09				
10				
11				
12				
13				
14				
15				
16				

1 2 3 4 5 6 7 8 9 10 11 12 13 14 15 16

2-MIL USE HOLE  
MAX LENGTH 7.4mm  
MIN LENGTH 2.0mm

SECTION X-Y  
SCALE 2:1

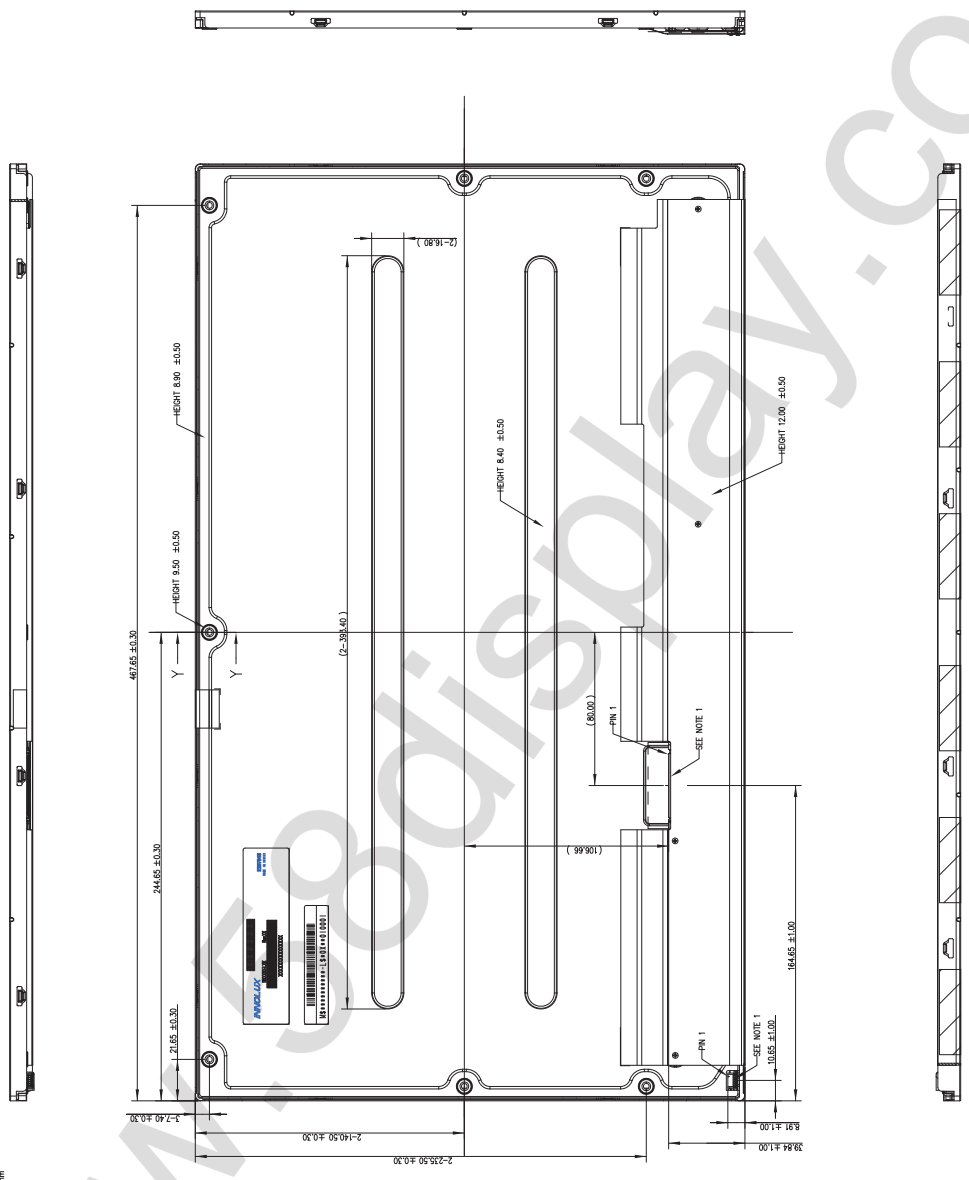

NOTE:  
1. THE DIMENSIONS SPECIFIED IN THIS DRAWING ARE IN MILLIMETERS.  
2. THE DIMENSIONS SPECIFIED IN THIS DRAWING ARE IN MILLIMETERS.  
3. THE DIMENSIONS SPECIFIED IN THIS DRAWING ARE IN MILLIMETERS.  
4. THE DIMENSIONS SPECIFIED IN THIS DRAWING ARE IN MILLIMETERS.  
5. DIMENSIONS OF THE USER HOLE SHOULD BE WITHIN 6 Hg±0.05.  
6. Display area position tolerance: |A-B| ≤ 18 |C-D| ≤ 1

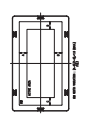

DATE	REV	BY	CHK	APP
2014.11.10	01	WANG	WANG	WANG
2014.11.10	02	WANG	WANG	WANG
2014.11.10	03	WANG	WANG	WANG
2014.11.10	04	WANG	WANG	WANG
2014.11.10	05	WANG	WANG	WANG
2014.11.10	06	WANG	WANG	WANG
2014.11.10	07	WANG	WANG	WANG
2014.11.10	08	WANG	WANG	WANG
2014.11.10	09	WANG	WANG	WANG
2014.11.10	10	WANG	WANG	WANG
2014.11.10	11	WANG	WANG	WANG
2014.11.10	12	WANG	WANG	WANG
2014.11.10	13	WANG	WANG	WANG
2014.11.10	14	WANG	WANG	WANG
2014.11.10	15	WANG	WANG	WANG
2014.11.10	16	WANG	WANG	WANG